

1. Pipes Diameter Range: Ø600mm to Ø900mm
 2. *Inlet and Outlet openings are core drilled by Hynds at Factory
 3. Contractor to provide and epoxy Inlet & Outlet Pipe Shorts to Manhole, Maximum allowable inlet/outlet pipe grade of 1:100
 4. *Minimum angle between inlet and outlet must be 90 degrees. This General Arrangement drawing represents a standard DDS supplied with single inlet.
 5. For multiple inlets (maximum of 3), minimum angle between any connections must be 90 degrees. Additional inlet chutes to be priced separately. DDS with multiple inlets will be a made-to-order design.
 6. Standard Manhole Lid designed to HD60 Vehicle Loads
 7. For install in B2 Exposure Classification environment, consult with Hynds if C or U exposure classification is required
 8. Varied depths can be achieved by placement of additional manhole Risers or adjustment Rings on top of standard units shown
 9. Joint sealing between Manhole Riser joints and Pipe connection into manholes - Contractors care
- * Check Hynds Manhole Data sheets for guidance as to Maximum allowable openings and Minimum distance between pipes

Pipe Details	Inlet Pipe	Outlet Pipe
Pipe Type (Concrete, PVC, PE, Other)		
Pipe Class (If Concrete)		
Nominal ID		
Outside Diametre		
Inlet Pipe Angle		N/A

Please Note:
 Invert Dimensions may be subject to minor changes.
 Check with Hynds Stormwater Team prior to conformation of order to confirm details.

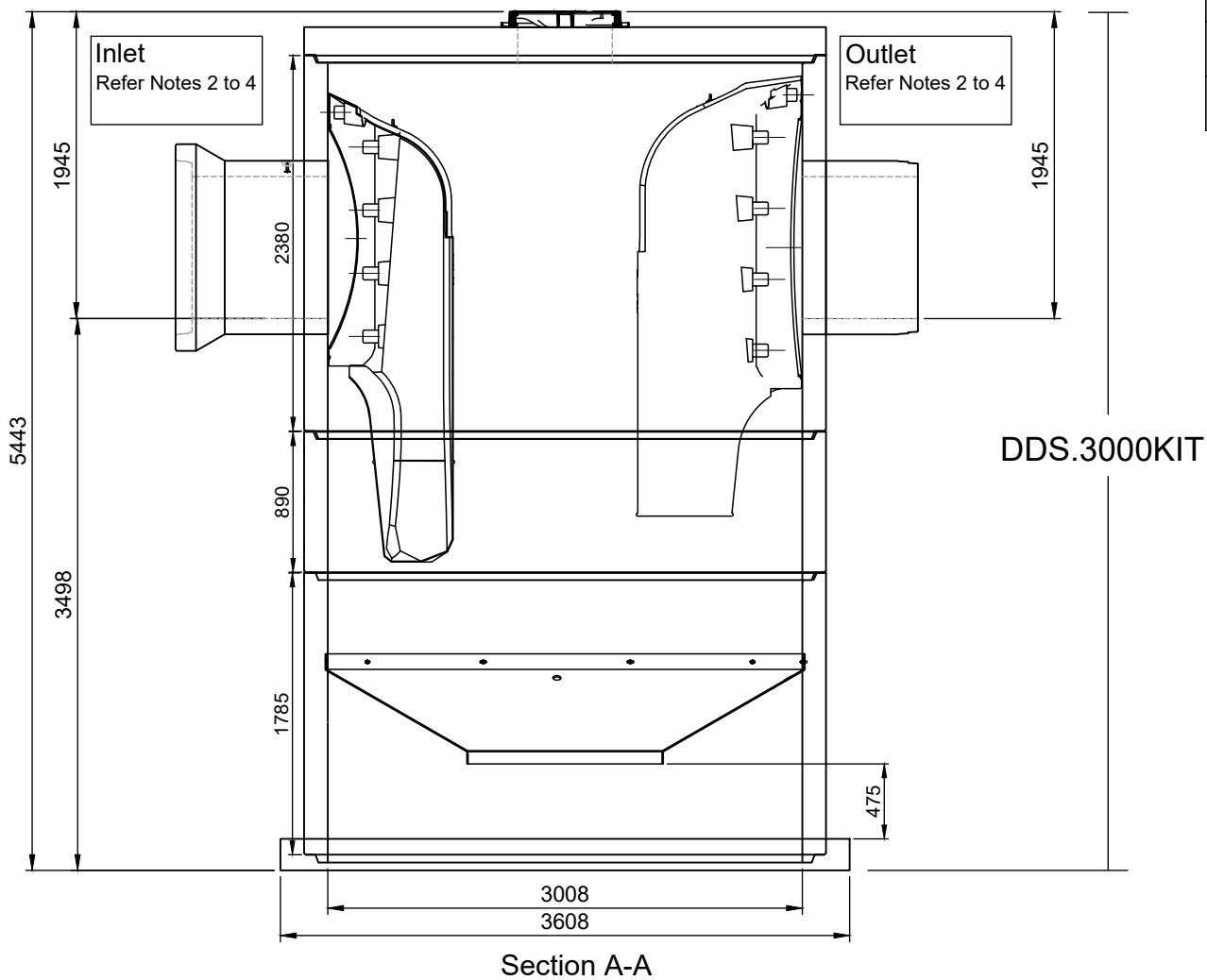

I AUTHORISE **HYNDS PIPE SYSTEMS LTD** TO PROCEED WITH THE MANUFACTURING OF THIS PIPE SPECIAL AS DETAILED
 I ACKNOWLEDGE THAT ANY SPECIALS, ONCE MANUFACTURED, ARE DEEMED TO BE MY (CONTRACTOR'S) PROPERTY & ARE NON REFUNDABLE. STORAGE & HANDLING FEES WILL BE INCURRED FOR PRODUCTS THAT ARE NOT DELIVERED/COLLECTED WITHIN 1 MONTH OF THE DATE AGREED AT THE TIME OF ORDER. PRODUCT NOT DELIVERED/COLLECTED WITHIN 3 MONTHS OF THE DATE AGREED MAYBE DESTROYED AT MY EXPENSE.

NAME :- SIGNATURE :-
 DATE :-

NOTES:

MATERIALS

VOL (m³/unit) = -
 WT (ton/unit) = -
 CODE = DDS.3000KIT

REVISIONS

REV #	REVISION DESCRIPTION:	DATE:	DRAWN:
1	Issued For Approval	26 May 2023	GH
2	Bottom Brackets Deleted, Top Dowle Bars Added	29 May 24	GH
---	---	---	---
---	---	---	---
---	---	---	---
---	---	---	---
---	---	---	---

PO Box 58142, Botany, Auckland, 2163
 Tel: 09-274 0316
 Fax: 09-272 7485
 email: technicalservices@hynds.co.nz



© 2023 HYNDS PIPE SYSTEMS LTD
 This drawing is the property of Hynds Pipe Systems Limited. Not to be disclosed to any other person without permission from Hynds Pipe Systems Limited. It is submitted for use only in connection with proposals and contracts of Hynds Pipe Systems Limited upon the express condition that it is not to be reproduced or copied in any form. Data to be used only with reference to products manufactured and supplied by Hynds Pipe Systems Limited.

ISO 9001 CERTIFIED MANAGEMENT SYSTEM

PROJECT DESCRIPTION:
 Hynds Pipe Systems
 Stormwater
 Downstream Defender Selec

SERVICE DETAIL:
 Downstream Defender Select 3000
 Concrete Advance Vortex
 Precast Manhole Ø3000
 General Arrangement

REFERENCE/QUOTE NUMBER: -

DRAWN: GH	DESIGN: GH BH	CHECKED: GH
SIGNATURE:	SIGNATURE:	SIGNATURE:
SCALE: 1:40	Note: Do not scale drawing if in doubt ASK!!!	DATE: 29-Jan-25
PAPER SIZE: A3		
DRAWING NUMBER: T8535 1	SHEET NUMBER: 1 of --	REVISION NUMBER: 2