

- NOTE:**
- Varied depths can be achieved by placement of additional riser sections or Lid adjustment Rings on top of the standard unit shown.
 - The Outlet Pipe can be positioned at any angle between 90° and 270° to meet site requirements
Supplied in default position of 180° unless specified below

OUTLET ORIENTATION

Please provide required outlet angle (degrees)

DI Manhole Access cover & Frame with Ø600 Opening

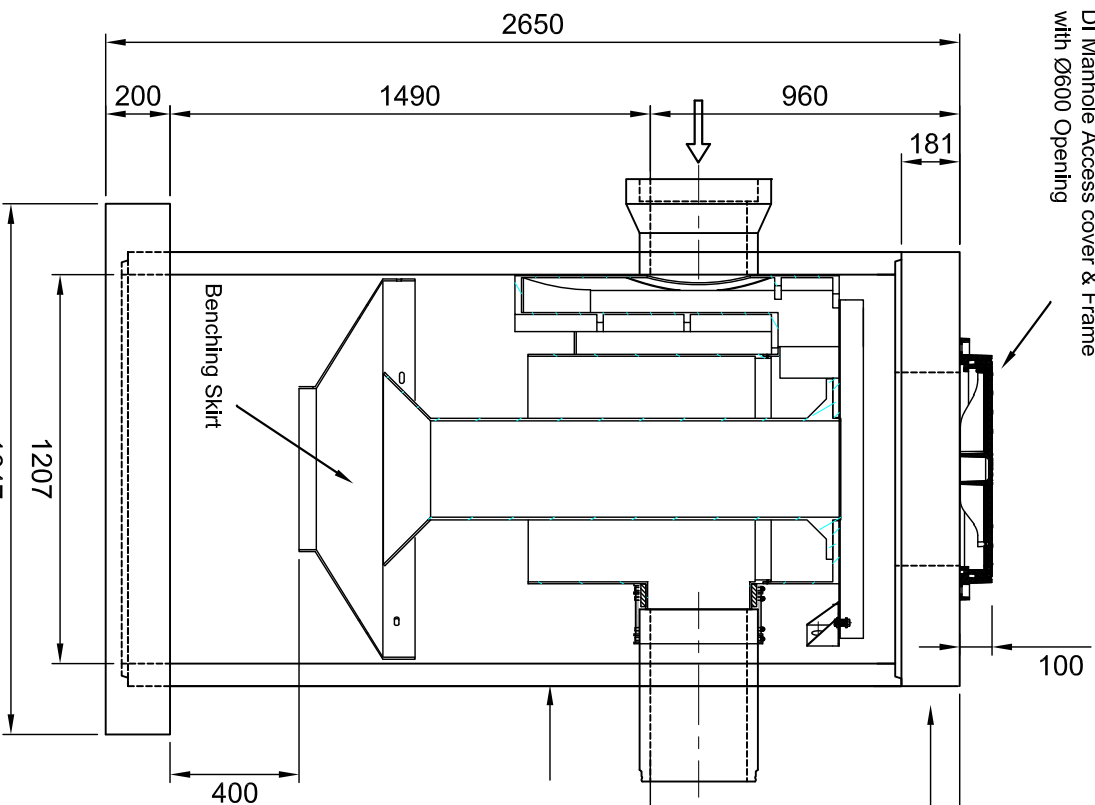

HN:HO-72 Manhole Lid Ø1200 x200mm Thk, Ø605 Hole centrally located
Code LD12200HN6
Weight = 0.580 Tonne

DD3 Kit: 300 - 300
FB12002400, Flanged Base Riser Ø1200x2400 High
Supplied complete with DD3 internals
Weight = 2.55 Tonne

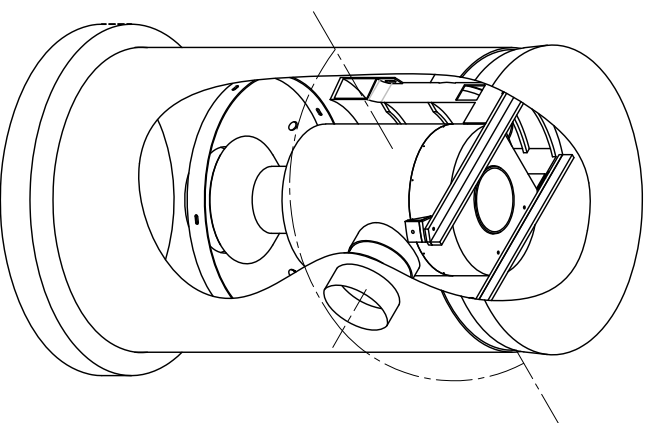

I AUTHORISE **HYNDS PIPE SYSTEMS LTD** TO PROCEED WITH THE MANUFACTURING OF THIS PIPE SPECIAL AS DETAILED
I ACKNOWLEDGE THAT ANY SPECIALS, ONCE MANUFACTURED, ARE DEEMED TO BE MY (CONTRACTORS) PROPERTY & ARE NON REFUNDABLE. STORAGE & HANDLING FEES WILL BE INCURRED FOR PRODUCTS THAT ARE NOT DELIVERED/COLLECTED WITHIN 1 MONTH OF THE DATE AGREED. AT THE TIME OF ORDER, PRODUCT NOT DELIVERED/COLLECTED WITHIN 3 MONTHS OF THE DATE AGREED MAYBE DESTROYED AT MY EXPENSE.

NAME :-
DATE :-

SIGNATURE :-

NOTES:

MATERIALS

VOL (m³/unit) = -
WT (ton/unit) = As Noted
CODE = DD3.1200CONCKIT

REVISIONS

REV #	REVISION DESCRIPTION:	DATE:	DRAWN:
1	Issued For Construction	25 Feb 2020	GH

PO Box 58142, Botany, Auckland, 2163
Tel: 09-274 0316
Fax: 09-272 7485
email: technicalservices@hynnds.co.nz



©2020 HYNDS PIPE SYSTEMS LTD
This drawing is the property of Hynds Pipe Systems Limited. Not to be disclosed to any other person without permission from Hynds Pipe Systems Limited. It is submitted for use only in connection with proposals and contracts of Hynds Pipe Systems Limited upon the express condition that it is not to be reproduced or copied in any form. Data to be used only with reference to products manufactured and supplied by Hynds Pipe Systems Limited.

ISO 9001 CERTIFIED MANAGEMENT SYSTEM

PROJECT DESCRIPTION:
Hynds Pipe Systems
Downstream Defender DD3
Spun Manhole Version
General Detail

SERVICE DETAIL:
Downstream Defender
DD3 FB Ø1200x2400mm High
Spun Manhole Type
General Arrangement

REFERENCE/QUOTE NUMBER: (Tech Ref No.)

DRAWN: GH **DESIGN:** GH **CHECKED:-**
SIGNATURE: **SIGNATURE:** **SIGNATURE:**

SCALE: N.T.S **Note:** Do not scale drawing
PAPER SIZE: A3 **if in doubt ASK!!!** **DATE:** 27-Jan-20

DRAWING NUMBER: T7480 SI **SHEET NUMBER:** SI of -- **REVISION NUMBER:** 1