

Downstream Defender[®] Select

(Stormwater Treatment)

Technical Guide SW 13.1

The Downstream Defender[®] provides a high removal efficiency of settleable solids and floatable material over a wide range of flow rates

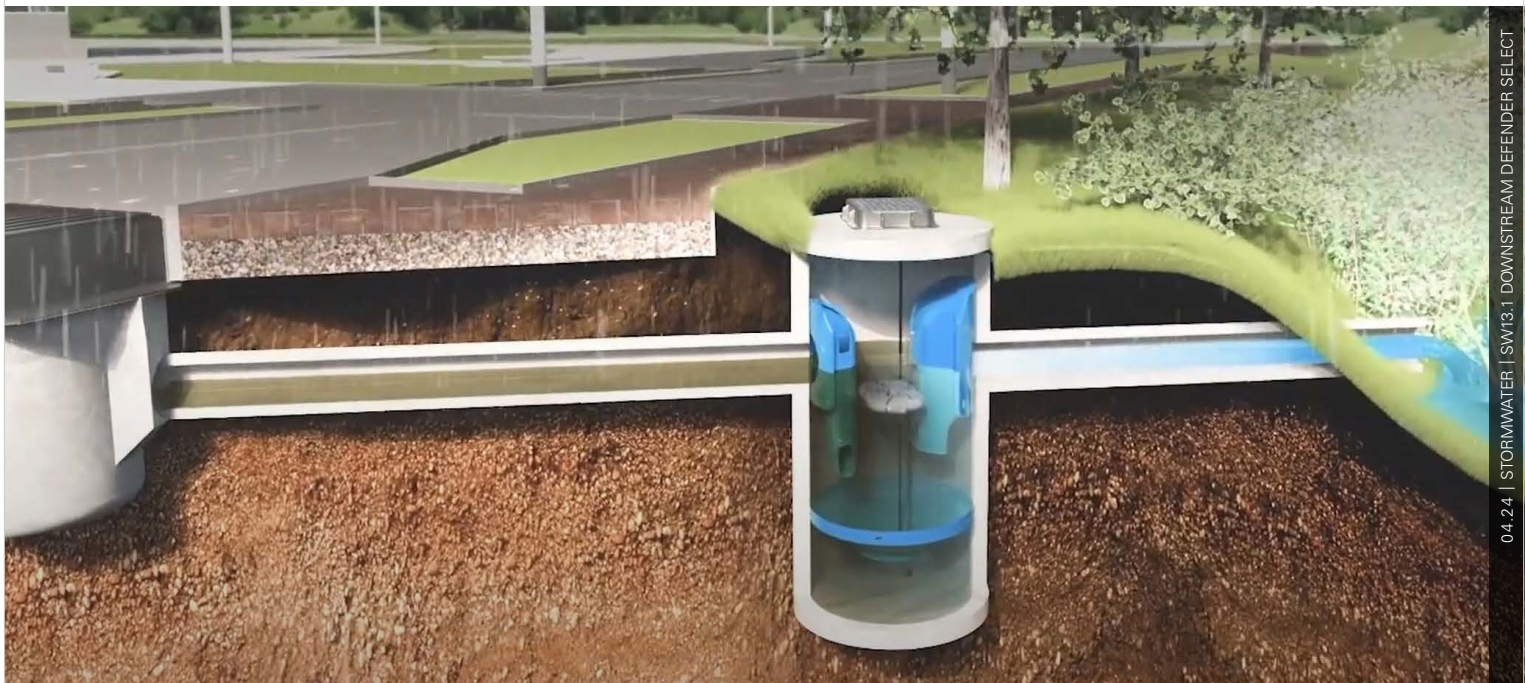

Applications

Roads, carparks, commercial properties

Ports, airports, construction sites

Industrial and commercial facilities

Control of silting upstream of wetlands, ponds and basins

Offline and online treatment of existing stormwater reticulation

Product Attributes

Removes up to 80% total suspended solids (TSS) with a mean particle size of 230 microns.

Removes sediments, floatables, oils and grease.

No re-entrainment of previously captured pollutants

Small footprint

Approvals/Standards

British Water Code of Practice

NZS3109, Concrete Construction

ISO 9001:2008 Quality Management Standard

We are the supply partner of choice for New Zealand's stormwater management and treatment solutions.

HYNDS
STORMWATER

The Hynds Downstream Defender® is an advanced hydrodynamic vortex separator designed to meet most stormwater regulations.

It provides highly effective and reliable removals of fine and coarse particles, hydrocarbons and other floatable debris from stormwater runoff, delivering high levels of treatment over a wide range of flow rates in a much smaller footprint. It is the perfect choice for any catchment likely to convey high quantities of contamination.

Design and Sizing

The Downstream Defender® is available in a range of sizes and can function as either a pretreatment device or as a stand alone device. The Hynds Downstream Defender® is sized to treat either a specified catchment area or a design flow rate to meet the water quality design for first flush treatment.

Benefits

- A smaller footprint ensures an easier installation and saves space and money
- Can be used in conjunction with other treatment types to create a treatment train effect.
- Easy to clean
- Can be used in back water environments
- Carefully designed internal components isolate the pollution storage areas ensuring what is captured is retained, even during high flows.

Targetted Pollutants

The Hynds Downstream Defender® removes an assortment of pollutants such as:

- Fine particles
- Floatable Debris
- Liquid and sediment bound hydrocarbons
- Sediment bound heavy metals
- Sediment bound nutrients

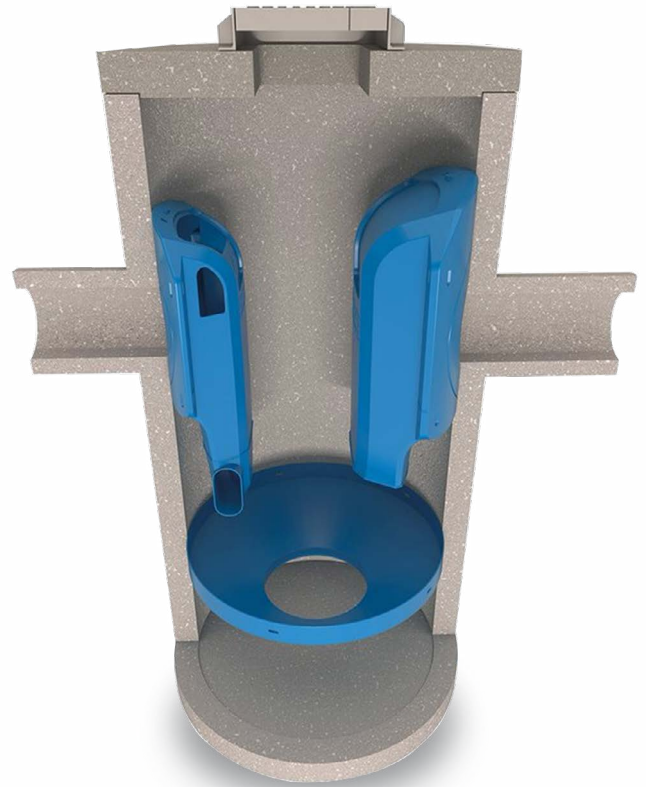

Installation

Treatment components are installed in a standard precast concrete manhole manufactured to AS/NZS and NZBC requirements.

The internals for the Ø1200, Ø1800 and Ø2550 are fitted at the factory. The Ø3000 comes with a fitted mounting bracket and bolt pack for the contractor to fit the chutes once the riser is unloaded – please refer to Page 2 of the DDS 3000 GA Drawing for details.

Inlet and Outlet openings are factory core-drilled by Hynds, contractor to provide and epoxy Inlet & Outlet Pipe shorts to manhole. Maximum inlet/outlet grade is 1:100

Note: Large Diameter Downstream Defenders may require an onsite crane to lift into the prepared excavation - refer to table 1 for indicative weight.

TABLE 1 Downstream Defender® variants

Diameter	Description	Weight of manhole with internal (Excluding lid) (T)	Weight of lid and cast iron and frame (T)
1200	Ø1200 x 2400mmH Flanged based manhole	3.22	0.742
1800	Ø1800 x 3600mmH Flanged based manhole	8.89	1.876
2550	Ø2550 x 4300 mmH Flanged based manhole	19.61	3.3
3000	Ø3000 x 5100mmH Flanged based manhole	24.77	4.7

TABLE 2 Key parameters

Unit Size (mm)	Design Flow (L/s)	Hydraulic Capacity Flow with recommended pipe size (L/s)	Hydraulic Capacity Flow with maximum pipe size (L/s)	Head-loss at Design Flow (mm)	Head-loss at Capacity (mm)	Minimum Sediment Storage (m ³)	Minimum liquid Hydrocarbon(oil) storage up to Design Flow rate (L/s)
1200	47	84	107	280	500	0.45	442
1800	107	217	278	320	500	1.02	1458
2550	189	422	529	360	500	1.81	3586
3000	296	652	787	370	500	2.83	6811



Centre line of Inlet Pipe
can be located within the
180 Deg angle shown
(Refer to Hynds Manhole Data sheet for limitations)

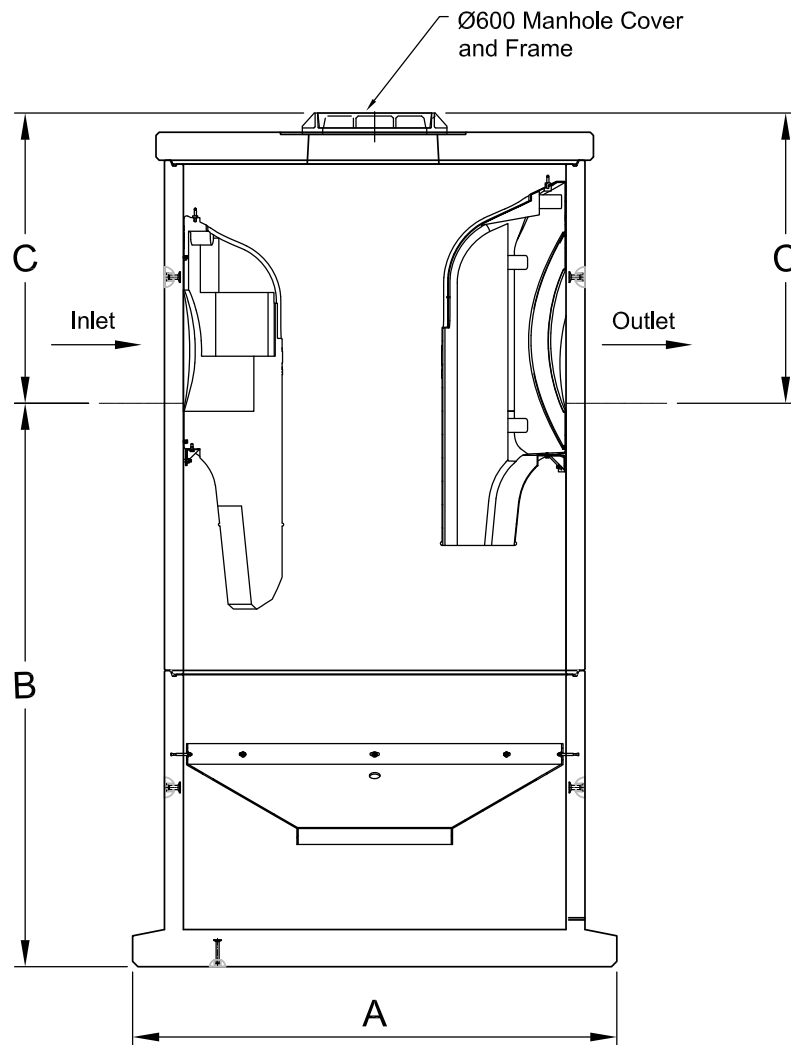
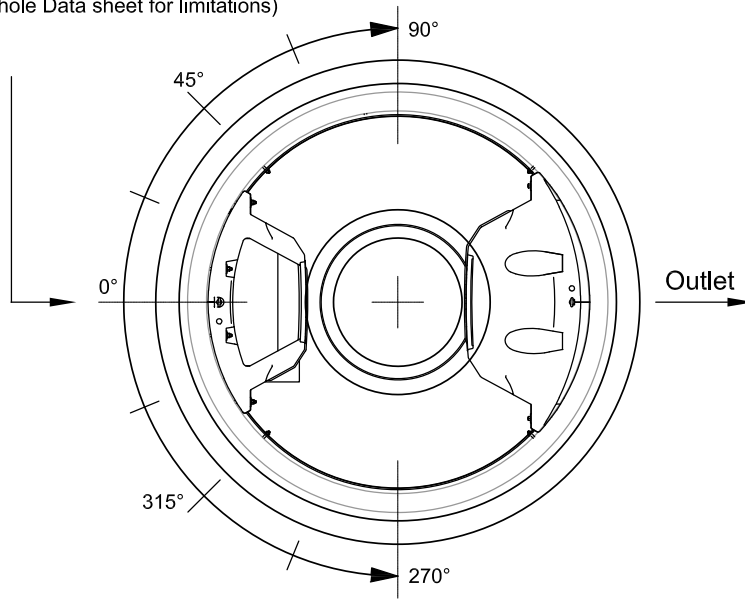

FIG. 1 Downstream Defender® Select concrete chamber dimension drawing

TABLE 3 Downstream Defender® Dimensions

Product Code	Mass Total (T)	Dimension			Minimum Pipe Diameter	Recommended Pipe Diameter (mm)	Maximum Pipe Diameter (mm)
		A (mm)	B (mm)	C (mm)			
DDS.1200KIT	3.9	1640	1740	1050	150	300	375
DDS.1800KIT	10.7	2278	2650	1365	375	450	600
DDS.2550KIT	22.7	3150	2995	2030	500	600	750
DDS.3000KIT	28.8	3608	3500	1945	600	750	900

Note:

- Each chamber comes complete with a concrete lid, ductile iron cover and frame
- Suggested invert level is indicative only and may vary depending on inlet/outlet invert to finish floor levels. Prices may vary depending on your location
- The inlet pipe size must always be equal to or smaller than the outlet pipe size
- The recommended pipe size for optimum performance.

Maintenance / Servicing

The frequency of clean out is determined in the field after installation. During the first year of operation, the unit should be inspected every six months to determine the rate of sediment and floatables accumulation. A simple probe such as a Sludge-Judge can be used to determine the level of accumulated solids stored in the sump.

Activity	Indicative frequency for mid level catchment area
Inspection	Regularly during the first year of installation.
	Every 6 months after the first year of installation
Oil and Floatables removal	Once per year, with sediment removal
	Following a spill in the drainage area
Sediment Removal	Once per year or as needed
	Following a spill in the drainage area

Lifting and Handling

All Downstream Defenders® incorporate Swiftlift lifting anchors for safe lifting and must be used with the correct lifting clutch.

Hynds Pipe Systems has designed and manufactured Downstream Defenders® with a minimum dynamic factor of 1.2. This dynamic factor requires that all the following conditions are observed when lifting, moving or placing the units:

1. Lifting with mobile plant (*such as an excavator or similar*) where equipment is specifically exempt from the requirements of the PECPR Regulations 1999, subject to the conditions outlined in the New Zealand Gazette, No. 104, September 2015 and
2. Lifting, travelling and placing over rough or uneven ground where anchor failure is not anticipated to cause harm or injury, by adopting procedures such as:
 - a. Transporting the element as close as practical to ground level (300mm recommended)
 - b. Establishing and maintaining exclusion zones
 - c. Transporting only precast concrete elements that are unlikely to topple if they were to hit the ground
 - d. Inspecting lifting anchors both after transportation and before final lifting into place

Refer to "Safe work with precast concrete - Handling, transportation and erection of precast concrete elements" published by Worksafe New Zealand (October 2018)

Shock loads resulting from travelling with suspended Downstream Defenders® over rough terrain and uneven ground may exceed design, dynamic and safety factors of the lifting systems. It is essential that care is taken during lifting and transporting as additional stresses could result in anchor failure.

Branches Nationwide *Support Office & Technical Services 0800 93 7473*

Disclaimer: While every effort has been made to ensure that the information in this document is correct and accurate, users of Hynds product or information within this document must make their own assessment of suitability for their particular application. Product dimensions are nominal only, and should be verified if critical to a particular installation. No warranty is either expressed, implied, or statutory made by Hynds unless expressly stated in any sale and purchase agreement entered into between Hynds and the user.