

# TP800 600mm Bolt Down Covers & Grates

Technical Guide D16.17

Versatile, high quality performance Class D240kN Bolt Down Access Cover System where security is required.

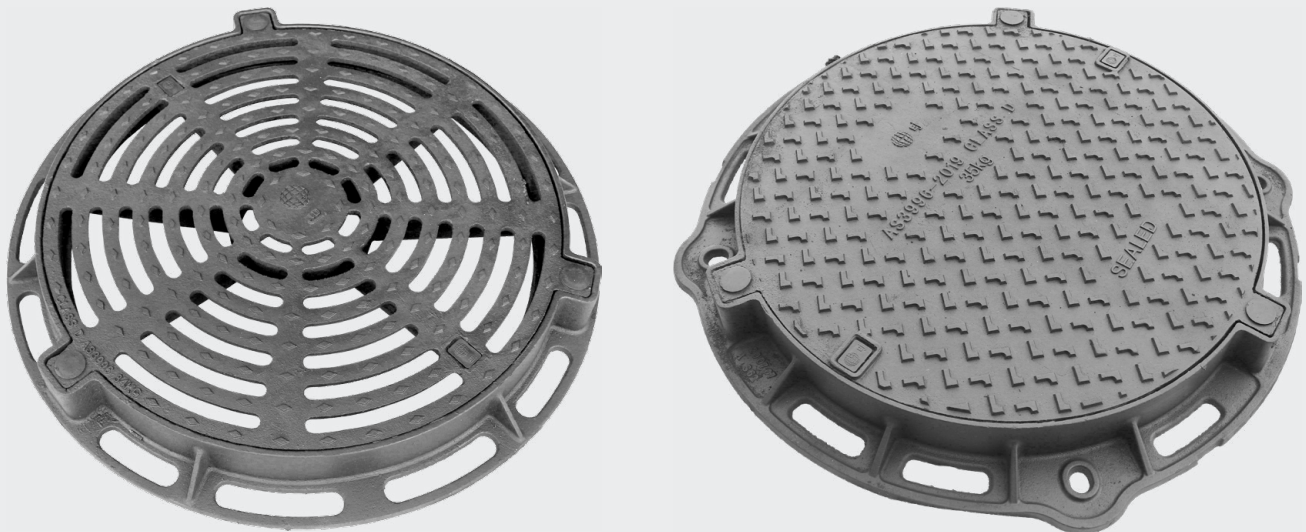

## Applications

Wastewater Networks  
Stormwater Networks  
Security applications  
Lighter trafficked conditions

## Product Attributes

600mm clear opening  
Bolt down with three locating points  
Covers can handle a back pressure of up to 1 Bar  
Available as a solid top cover or a grated cover

## Approvals/Standards

AS3996:2019 Class D240kN  
Meets HN-HO-72 Transit Load Requirement

## Quality

Manufactured to a high standard in Ductile Iron 500/10  
ISO9001:2015 Quality Management

*We are the supply partner of choice for New Zealand's civil construction industry, specialising in water and infrastructure based solutions.*

The TP800 range is a high quality long serving Ductile Iron bolt down cover and grate system that was originally designed for the European market and introduced into New Zealand to satisfy the need for a more security focused and flexible design.

### Features

- Gas and water-tight sealed to AS3996:2019
- Load rated to EN-124 Class C and AS3996:2019 Class D that meet NZTA requirement for HN-HO-72
- Triple Locating Points for easy maintenance.
- Locating point bolt down which can be upgraded to High Security bolting if required.
- Anti-Slip Surface (Patented 4L Design)
- The Frame and Grate option comes with a built in Anti-rattle ring and an Anti-slip diamond pattern surface and has been designed for High Flow applications.

### Testing

- ALS Global load and water tightness testing
- IAPMOMark as 3rd party certified to AS3996:2019
- Quality ISO9001:2015

### Dimensions

- Clear Opening – 600mm
- Overall Dimension – 852mm
- Depth of frame – 75mm

### Product Range

**TABLE 1 TP800 Range**

Code	Description
DIMHCFTP800	TP800 Access Cover Ø 600 Bolt Down
DIMHCFTP800-SEW	TP800 Access Cover Ø 600 Bolt Down Sewer
DIMHCFTP800-STW	TP800 Access Cover Ø 600 Bolt Down Stormwater
DIMHGFTP800	TP800 Grate and Frame Ø 600 Bolt Down

**Flow Rate Estimate TP800DG**

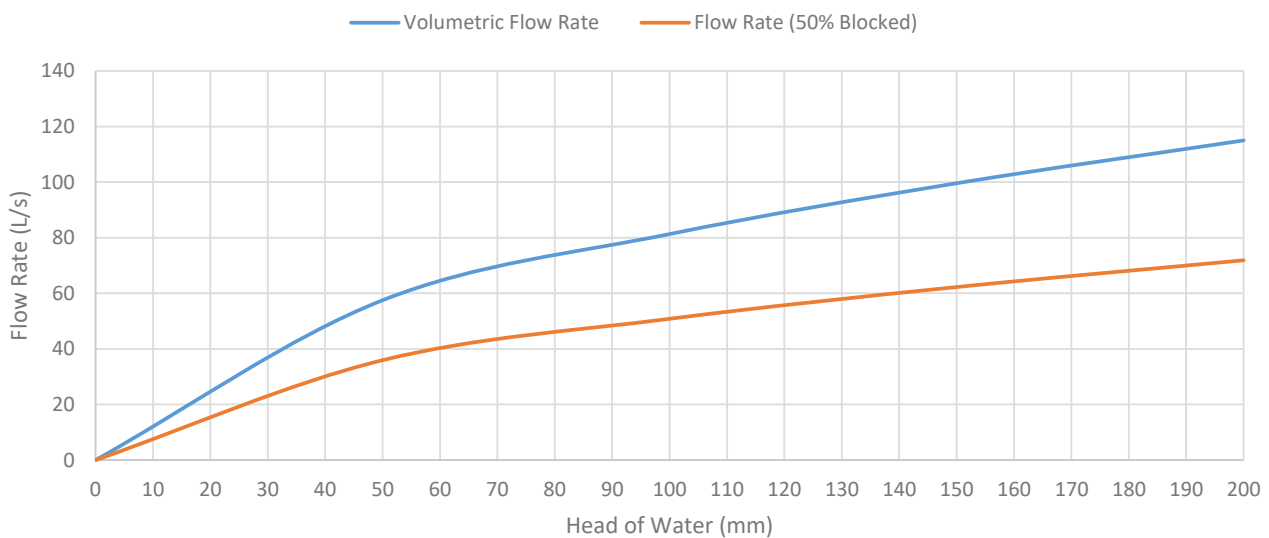

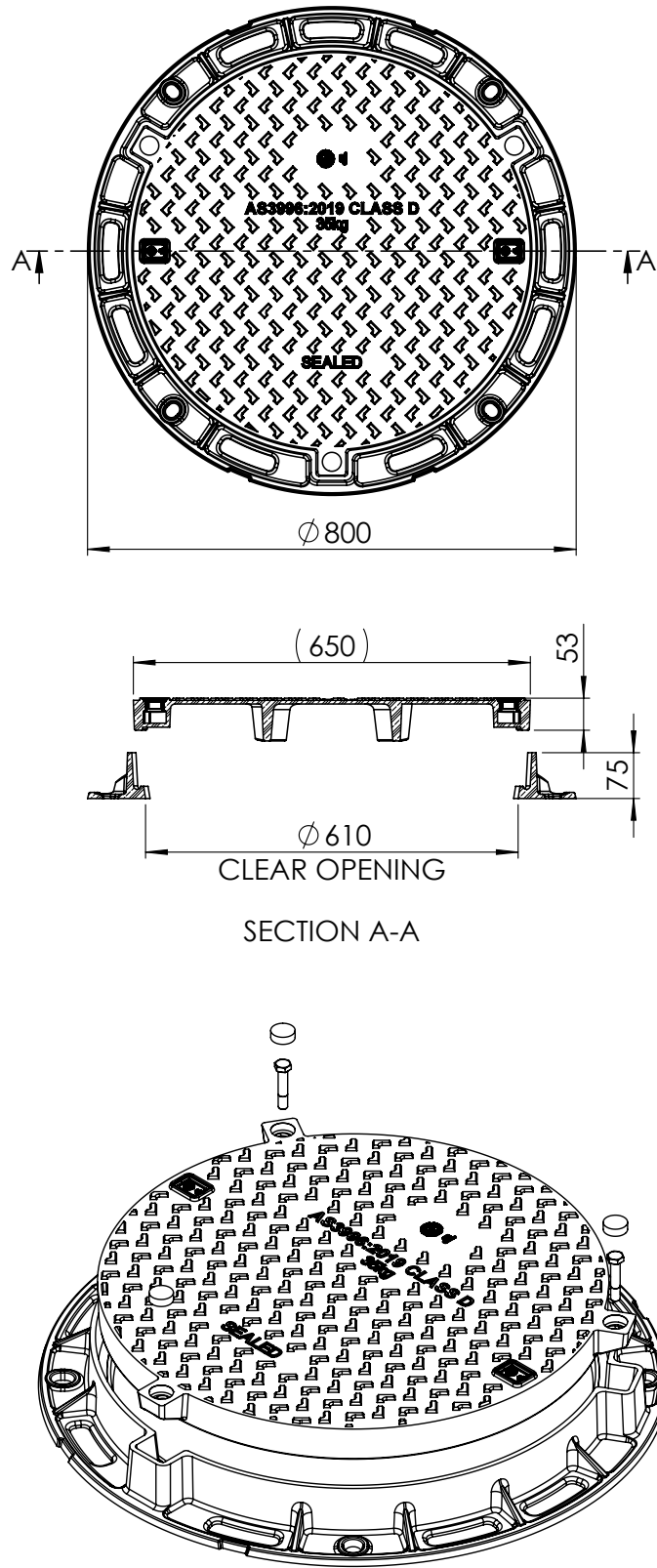
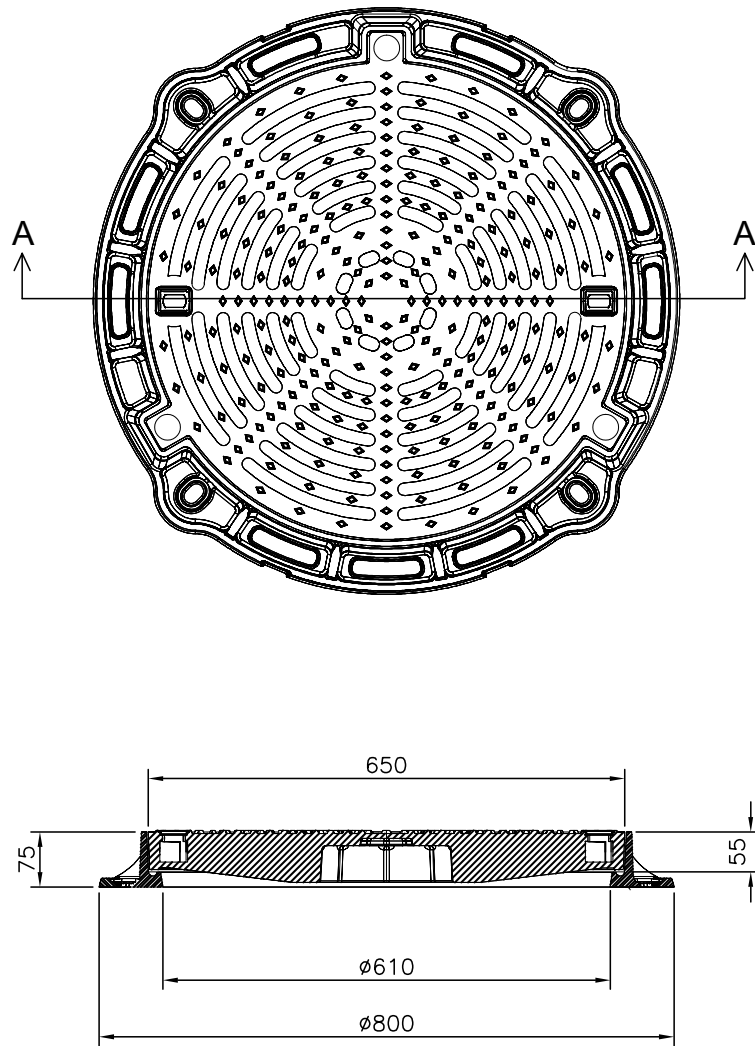

FIG. 1 TP800 Bolt Down Cover Drawing



### Section A-A

FIG. 2 TP800 Bolt Down Grate Drawing

Branches Nationwide Support Office & Technical Services 0800 93 7473

**Disclaimer:** While every effort has been made to ensure that the information in this document is correct and accurate, users of Hynds product or information within this document must make their own assessment of suitability for their particular application. Product dimensions are nominal only, and should be verified if critical to a particular installation. No warranty is either expressed, implied, or statutory made by Hynds unless expressly stated in any sale and purchase agreement entered into between Hynds and the user.